

# TOSHIBA SEMICONDUCTOR TECHNICAL DATA

TOSHIBA TRANSISTOR  
2SD1554

SILICON NPN TRIPLE DIFFUSED MESA TYPE

COLOR TV HORIZONTAL OUTPUT APPLICATIONS.

**FEATURES:**

- High Voltage :  $V_{CBO}=1500V$
- Low Saturation Voltage:  $V_{CE(sat)}=5V(Typ.) (I_C=3A, I_B=0.8A)$
- High Speed :  $t_f=1.0\mu s(Max.) (I_{CP}=3A, I_{B1}(end)=0.8A)$
- Built-in Damper Type
- Glass Passivated Collector-Base Junction
- Collector Metal (Fin) is Fully Covered with Mold Resin.  
(IS Package)

**MAXIMUM RATINGS ( $T_c=25^\circ C$ )**

CHARACTERISTIC	SYMBOL	RATING	UNIT
Collector-Base Voltage	$V_{CBO}$	1500	V
Collector-Emitter Voltage	$V_{CEO}$	600	V
Emitter-Base Voltage	$V_{EBO}$	5	V
Collector Current	$I_C$	3.5	A
Base Current	$I_B$	1	A
Collector Power Dissipation	$P_C$	40	W
Junction Temperature	$T_j$	150	$^\circ C$
Storage Temperature Range	$T_{stg}$	-55~150	$^\circ C$

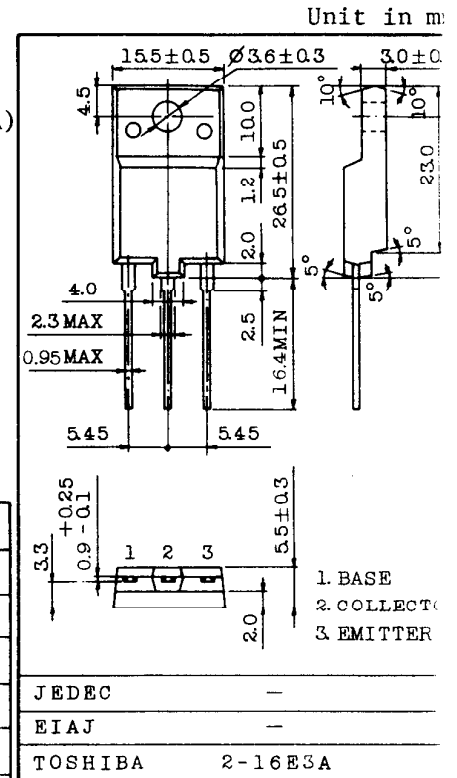

**EQUIVALENT CIRCUIT**

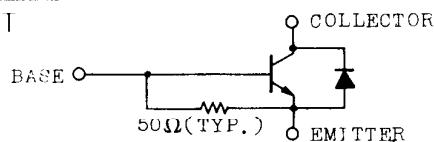

**ELECTRICAL CHARACTERISTICS ( $T_c=25^\circ C$ )**

CHARACTERISTIC	SYMBOL	TEST CONDITION	MIN.	TYP.	MAX.	UNIT
Collector Cut-off Current	$I_{CBO}$	$V_{CB}=500V, I_E=0$	-	-	10	$\mu A$
Emitter-Base Breakdown Voltage	$V_{(BR)EBO}$	$I_E=200mA, I_C=0$	5	-	-	V
DC Current Gain	$h_{FE}$	$V_{CE}=5V, I_C=0.5A$	8	12	-	
Collector-Emitter Saturation Voltage	$V_{CE(sat)}$	$I_C=3A, I_B=0.8A$	-	5	8	V
Base-Emitter Saturation Voltage	$V_{BE(sat)}$	$I_C=3A, I_B=0.8A$	-	-	1.5	V
Forward Voltage (Damper Diode)	$-V_F$	$I_F=3.5A$	-	1.6	2.0	V
Transition Frequency	$f_T$	$V_{CE}=10V, I_C=0.1A$	-	3	-	MHz
Collector Output Capacitance	$C_{ob}$	$V_{CB}=10V, I_E=0, f=1MHz$	-	95	-	pF
Fall Time (Fig.)	$t_f$	$I_{CP}=3A, I_{B1}(end)=0.8A$	-	0.5	1.0	$\mu s$

The information contained herein is presented only as a guide for the applications of our products. No responsibility is assumed by TOSHIBA for any infringements of patents or other rights of the third parties which may result from its use. No license is granted by implication or otherwise under any patent or patent rights of TOSHIBA or others.

2SD1554-1

1990-1-20

TOSHIBA CORPORATION

Fig.  $t_f$  TEST CIRCUIT

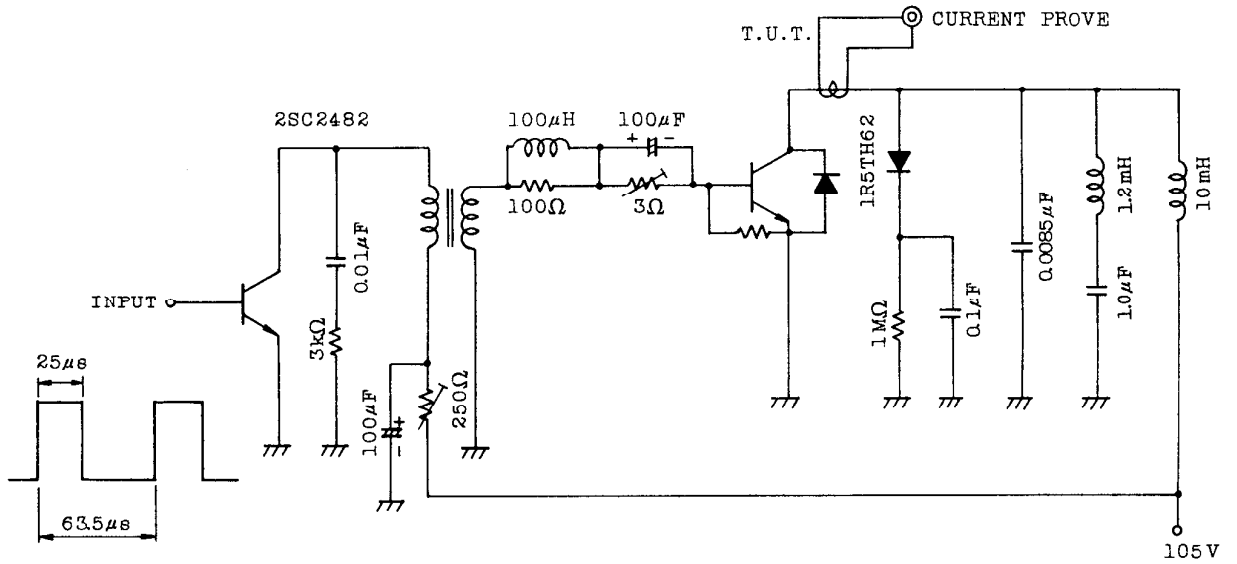

BASE CURRENT

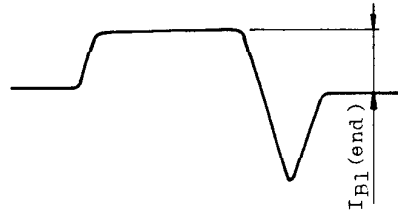

COLLECTOR CURRENT

