



# SPECIFICATION

## For

# APPROVAL

Preliminary Specification

Final Specification

Title	15.1" XGA TFT LCD
-------	-------------------

<b>BUYER NAME</b>	
<b>MODEL NAME</b>	

<b>SUPPLIER</b>	<b>LG Electronics Inc.</b>
<b>MODEL NAME</b>	<b>LM151X2</b>

SIGNATURE	DATE
/	_____
/	_____
/	_____

APPROVED BY	DATE
<b>H. Yoon</b> /G.Manager	_____
<b>REVIEWED BY</b>	
<b>I. H. Ahn</b> /S.Engineer	_____
<b>PREPARED BY</b>	
<b>G. T. Kim</b> /S.Engineer	_____

**Please return 1 copy for our confirmation with your signature and comments.**

**Product Engineering Dept.  
LCD Division LG Electronics Inc.**

CONTENTS

NO.	ITEM	Page
-	COVER	1
-	CONTENTS	2
-	RECORD of REVISION	3
1.	GENERAL DESCRIPTION	4
2.	MAXIMUM RATINGS	5
3.	ELECTRICAL SPECIFICATIONS	5
4.	OPTICAL SPECIFICATIONS	6
5.	INTERFACE CONNECTIONS	10
6.	SIGNAL TIMING SPECIFICATIONS	11
7.	SIGNAL TIMING WAVEFORMS	12
8.	COLOR INPUT DATA REFERENCE	13
9.	POWER SEQUENCE	14
10.	MECHANICAL CHARACTERISTICS	15
11.	ENVIRONMENTAL SPECIFICATION	16
12.	INCOMING INSPECTION STANDARD FOR TFT-LCD	17~19
13.	DESIGNATION OF LOT MARK	20
14.	PACKING FORM	20
15.	PRECAUTIONS	21
16.	APPENDIX 1. OUTLINE DRAWING	22~23
17.	APPENDIX 2. PACKING ASSEMBLY DRAWING	24~25
18.	APPENDIX 3. CLASSIFICATION OF DEFECTS	26



**Record of Revision**

<b>Revision Version</b>	<b>Date</b>	<b>DESCRIPTION</b>
<b>0.0</b>	<b>April 13, 1998</b>	<b>Preliminary</b>
<b>0.1</b>	<b>May 6, 1998</b>	<b>Preliminary, Update (Changed Interface Connections - Increased V<sub>DD</sub> Lines, Fixed Interface Connector Model Name, Updated Outline Drawing)</b>

## 1. General Description

The LG Electronics model LM151X2 LCD is a Color Active Matrix Liquid Crystal Display with an integral Cold Cathode Fluorescent Tube(CCFT) back light system. The matrix employs a-Si Thin Film Transistor as the active element. It is a transmissive type display operating in the normally white mode. This TFT-LCD has a 15.1 inch diagonally measured active display area with XGA resolution(768 vertical by 1024 horizontal pixel array). Each pixel is divided into Red, Green and Blue sub-pixels or dots which are arranged in vertical stripes. Gray scale or the brightness of the sub-pixel color is determined with a 6-bit gray scale signal for each dot, thus, presenting a palette of more than 262,144 colors.

LM151X2 has been designed to apply the CMOS logic level interface.

The LM151X2 LCD is intended to support applications where high brightness, wide viewing angle, high color saturation, and high color depth are very important. In combination with the vertical arrangement of the sub-pixels, the LM151X2 characteristics provide an excellent flat panel display for office automation products such as monitors.

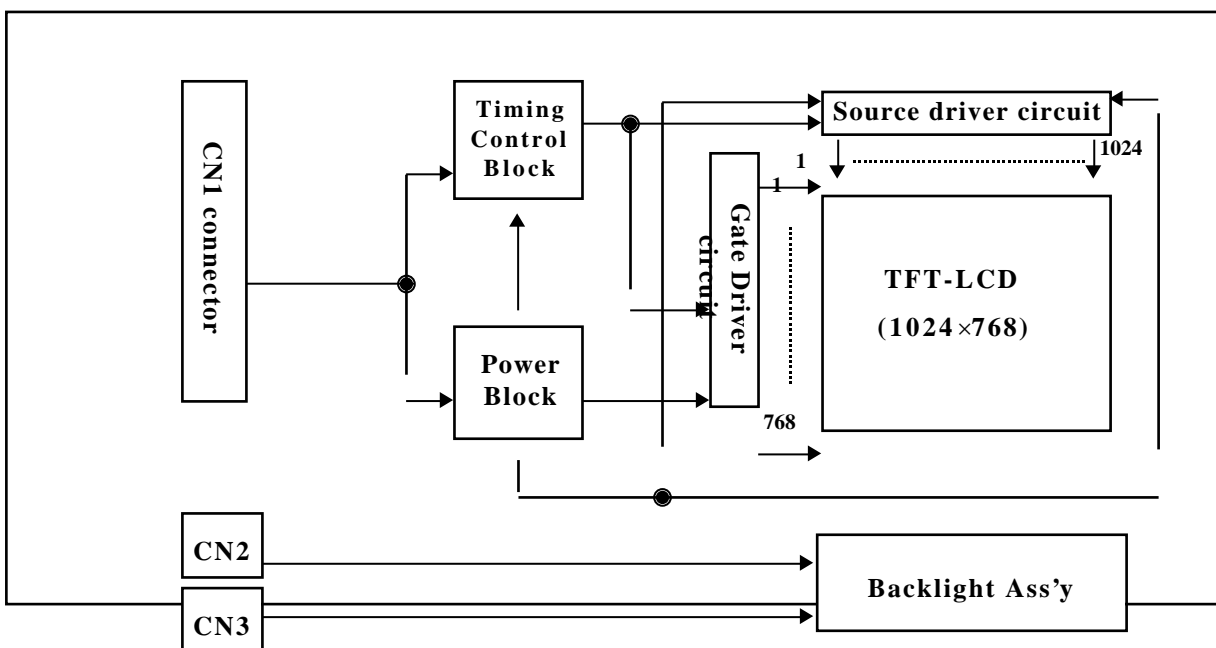

### General Display Characteristics

The following are general features of the model LM151X2 LCD;

Active display area	15.1 inches(38cm) diagonal
Outsize dimensions	352.6w * 264.6h * 16.0t(typ)mm(Without Inverter and User Connector)
Pixel pitch	0.30 mm $\phi$ 0.30 mm
Pixel format	1024 horiz. By 768 vert. pixels
	RGB vertical stripe arrangement
Color depth	6-bit, 262,144 colors
Display operating mode	transmissive mode, normally white
Surface treatments	hard coating(3H),



**Product Specification (preliminary)**

anti-glare treatment of the front polarizer

**Product Specification (preliminary)**

## 2. Maximum Ratings

The following are maximum values which, if exceeded, may cause faulty operation or damage to the unit.

Table 1 ABSOLUTE MAXIMUM RATINGS

Parameter	symbol	Values		Units	Notes
		Min.	Max.		
Power Input Voltage	$V_{DD}$	-0.3	+3.6	$V_{DC}$	at 25°...
Operating Temperature	$T_{OP}$	0	+50	°...	
Storage Temperature	$T_{ST}$	-20	+60	°...	1

Note: 1. The Relative Humidity must not exceed 95% non-condensing at temperatures of 40°... or less. At temperatures greater than 40°..the wet bulb temperature must not exceed 39°...

## 3. Electrical Specifications

The LM151X2 requires two power inputs. One input is employed to power the LCD electronics and to drive the voltages to drive the TFT array and liquid crystal. And the second input for the backlight CCFL, is typically generated by an inverter. The inverter is an external unit to the LCD.

Table 2 ELECTRICAL CHARACTERISTICS:

Parameter	Symbol	Values			Units	Notes
		Min.	Typ.	Max.		
MODULE :						
Power Supply Input Voltage	$V_{DD}$	3.15	3.3	3.45	$V_{DC}$	1
Power Supply Input Current	$I_{DD}$	-	1.0	TBD	A	1, 2
Data Input High Voltage	$V_{IH}$	$0.7 \times V_{DD}$	-	$V_{DD} + 0.5$	V	1
Data Input Low Voltage	$V_{IL}$	-0.5	-	$0.3 \times V_{DD}$	V	1
BACK LIGHT :						
Back light Input voltage	$V_{BL}$	650	550	525	$V_{RMS}$	
Backlight Input Current	$I_{BL}$	3.0	8.0	9.0	mA	3
Lamp Kick-Off Voltage		840	-	-	$V_{RMS}$	At 25°@°...
		925	-	-	$V_{RMS}$	At 0°@°...
		1240	-	-	$V_{RMS}$	4
		1360	-	-	$V_{RMS}$	At 25°@°...
					$V_{RMS}$	At 0°@°...
Operating Frequency	$F_{BL}$	30	50	80	KHz	5
Life time		-	40,000	-	hours	6

Notes: 1. All values shall be measured at the user connection.

2. The input current shall be measured at  $V_{DD}$  of 3.3V at 25°..refresh rate of 60Hz, and clock frequency of 65MHz under 9 gray pattern.

3. The backlight input current shall be measured at the ground cable and does not include loss of external inverter.

4. Voltages at both ends of the lamp.

5. Voltages at secondary side of transformer using the balancing capacitor, 22pF in inverter. These voltages can be changed with customer's own design of inverter.

6. The life time is defined as the time at which brightness of lamp is 50% compare to that of initial value at the typical lamp current.

**Product Specification (preliminary)**

#### 4. Optical Specifications

Optical characteristics are determined after the unit has been 'ON' and stable for approximately 30 minutes in a dark environment at 25°...The values specified are at an approximate distance 50cm from the LCD surface at a viewing angle of and equal to 0° and aperture 1 degree. The test equipment is PhotoResearch Prichard SpectroRadiometer Model 1980B-SC or equivalent. The input signal voltage and timing specification are  $V_{DD}$  of 3.3V and VESA XGA @60Hz respectively. The input current of backlight is 8mA( $F_{BL} = 50KHz$ ) at the ground terminals.

Table 2 OPTICAL CHARACTERISTICS

Parameter	Symbol	Values			Units	Notes
		Min.	Typ.	Max.		
Contrast Ratio	CR	150	200	-		1
Average Brightness, white	$SB_{WH}$	170	200	-	cd/m <sup>2</sup>	2
Brightness Variation	$SB_V$	-	-	30	%	3
Response Time	$Tr$		45	60	msec	4
Rise Time	$Tr_R$	-	10	15		
Decay Time	$Tr_D$	-	35	45		
CIE Color Coordinates						
Red	$x_R$	TBD	TBD	TBD		
	$y_R$	TBD	TBD	TBD		
Green	$x_G$	TBD	TBD	TBD		
	$y_G$	TBD	TBD	TBD		
Blue	$x_B$	TBD	TBD	TBD		
	$y_B$	TBD	TBD	TBD		
White	$x_W$	TBD	TBD	TBD		
	$y_W$	TBD	TBD	TBD		
Viewing Angle by CR 10					degree, °	5
x axis, right (•'=0°)	•E	55	60	-		
x axis, left (•'=180°)	•E	55	60	-		
y axis, up (•'=90°)	•E	40	45	-		
y axis, down (•'=270°)	•E	40	45	-		
Half Luminance Angle					degree, °	6
x axis, right (•'=0°)	•E	50	-	-		
x axis, left (•'=180°)	•E	50	-	-		
y axis, up (•'=90°)	•E	35	-	-		
y axis, down (•'=270°)	•E	35	-	-		
Cross talk		-	-	4	%	7
Flicker		-	-	-30	dB	8
Gamma value		-	-	-		9

**Product Specification (preliminary)**

Notes 1. Contrast Ratio (CR) is defined mathematically as:

$$\frac{\text{(Surface Brightness with all white pixels)}}{\text{(Surface Brightness with all black pixels)}}$$

Contrast ratio shall be measured at the center of the display (Location 1).

2. Average Brightness is the average of brightness value at location 1 to 5 with all pixels displaying white.

$$B(\text{AVE}) = \frac{B_1 + B_2 + B_3 + B_4 + B_5}{5}$$

3. The variation in surface brightness,  $SB_V$  is defined as :

$$\frac{\text{Maximum } (B_1, B_2, \dots, B_{13}) - \text{Minimum } (B_1, B_2, \dots, B_{13})}{\text{Average } (B_1, B_2, \dots, B_5)} \times 100(\%)$$

Where B1 to B13 are the brightness with all pixels displaying white at 13 locations.

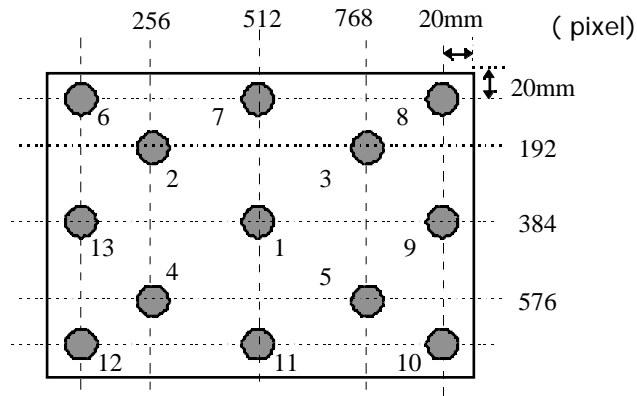

4. The response time is defined as the following figure and shall be measured by switching the input signal for "black" and "white".

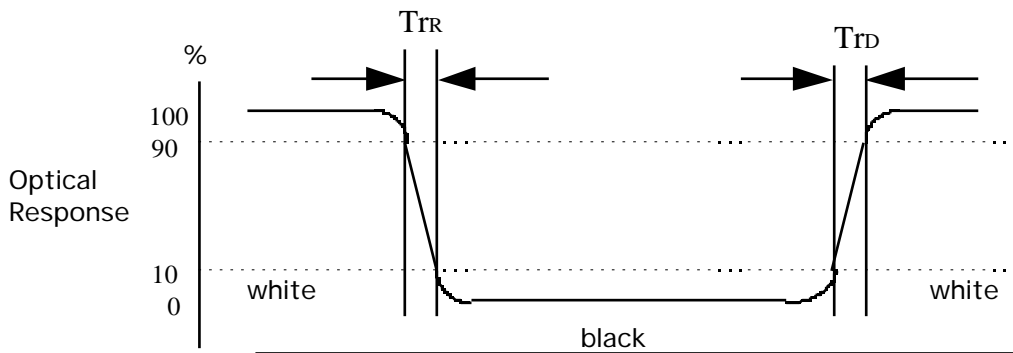



**Product Specification (preliminary)**

5. Viewing angle is the angle at which the contrast ratio is greater than 10.

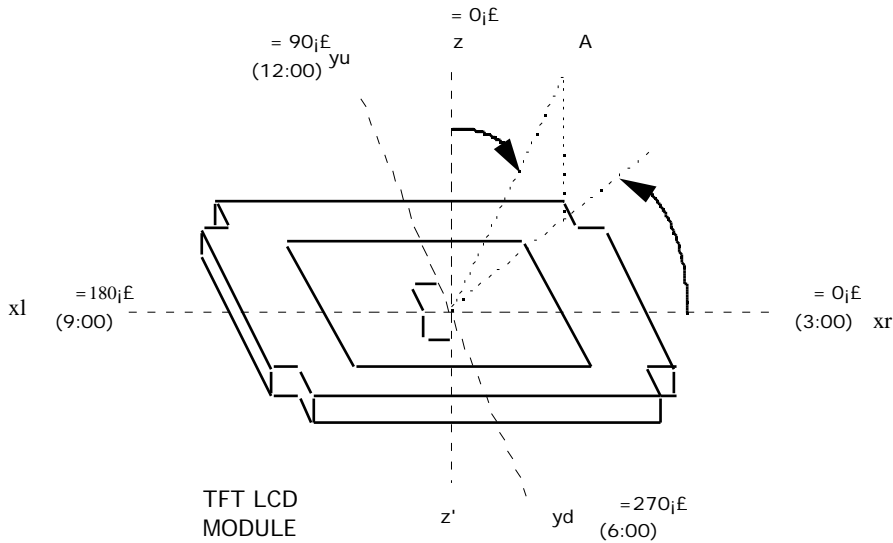

6. Half Luminance Angles

Half Luminance angles are defined as the up, down, left, and right angular boundaries at which the luminance value is 50% of the luminance value measured on-axis.

Measurements shall be done at the center of the display area (Location 1) with an all white image.

7. Cross talk shall be measured at center location.

$$\text{Crosstalk Ratio} = \frac{\text{Brightness at pattern A} - \text{Brightness at pattern B}}{\text{Brightness at pattern A}}$$

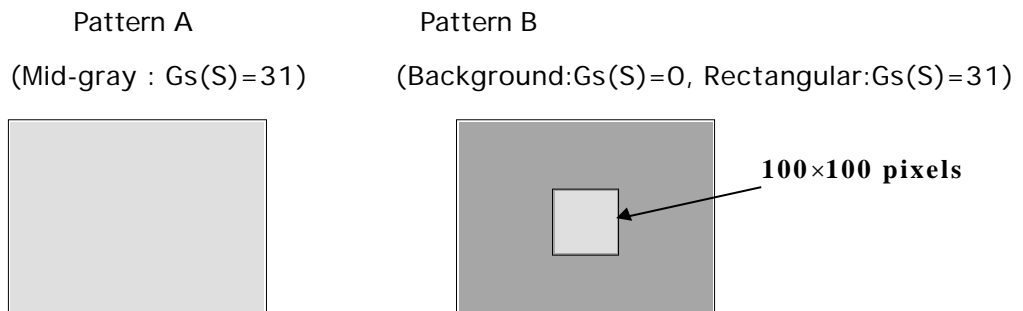

**Product Specification (preliminary)**

8. Flicker shall be measured at the center location.

Test pattern : Pixel pattern  
 Background RGB gray ( 0, 0, 0 )  
 Foreground RGB gray (31, 31, 31)

Test equation :  $20 \log \frac{\text{AC(at 30Hz)}}{\text{DC level}}$

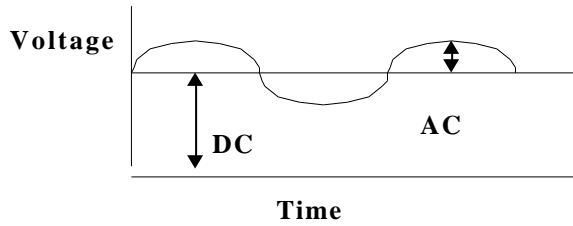

9. Gamma values shall be measured at the center location.

n	Gs(S)	Relative Brightness(%)		Remark
		min	max	
0	0	-	0.67	
1	7	-	TBD	
2	15	TBD	TBD	
3	23	TBD	TBD	
4	31	TBD	TBD	
5	39	TBD	TBD	
6	47	TBD	TBD	
7	55	TBD	TBD	
8	63	100	100	

**Product Specification (preliminary)**

**5. Interface Connections**

This LCD employs three interface connections, a 41 pin connector is used for the module electronics and two connectors, a three pin connector, are used for the integral backlight system. The electronics interface connector is a model DF9B-41P-1V manufactured by Hirose. The pin configuration for the connector is shown in the table below.

Table 3 MODULE CONNECTOR PIN CONFIGURATION

Pin	Symbol	Description	Pin	Symbol	Description
1	GND	System Ground. Note 1	2	DCLK	Data Input Clock
3	GND	System Ground	4	H <sub>sync</sub>	H <sub>sync</sub> : Horizontal Sync Signal
5	V <sub>sync</sub>	V <sub>sync</sub> : Vertical Sync Signal	6	GND	System Ground
7	GND	System Ground	8	GND	System Ground
9	R0	Red data 0 (LSB)	10	R1	Red data 1
11	R2	Red data 2	12	GND	System Ground
13	R3	Red data 3	14	R4	Red data 4
15	R5	Red data 5 (MSB)	16	GND	System Ground
17	GND	System Ground	18	GND	System Ground
19	G0	Green data 0 (LSB)	20	G1	Green data 1
21	G2	Green data 2	22	GND	System Ground
23	G3	Green data 3	24	G4	Green data 4
25	G5	Green data 5 (MSB)	26	GND	System Ground
27	GND	System Ground	28	GND	System Ground
29	B0	Blue data 0 (LSB)	30	B1	Blue data 1
31	B2	Blue data 2	32	GND	System Ground
33	B3	Blue data 3	34	B4	Blue data 4
35	B5	Blue data 5 (MSB)	36	GND	System Ground
37	DE	Data Enable Signal	38	V <sub>DD</sub>	No Connection
39	V <sub>DD</sub>	Power Supply for LCD Module	40	V <sub>DD</sub>	Power Supply for LCD Module
41	V <sub>DD</sub>	No Connection			

Notes: 1. All GND(ground) pins should be connected together and to Vss which should also be connected to the LCD's metal frame.  
 2. All V<sub>DD</sub>(power input) pins should be connected together.

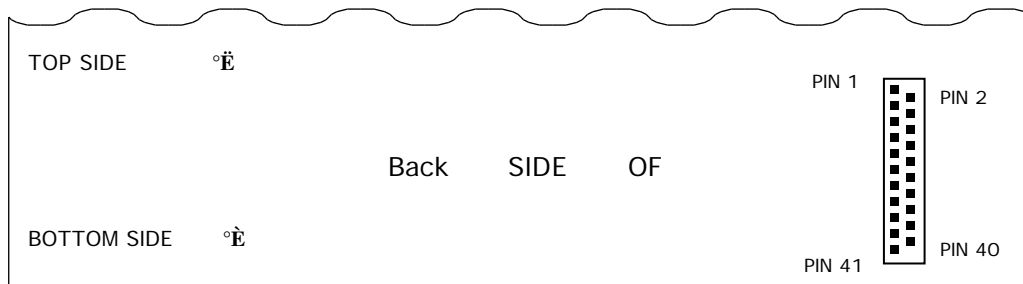

The backlight interface connector is a model BHR-03VS-1, manufactured by JST. The mating connector part number is SMO2(8.0)B-BHS-1-TB or equivalent. The pin configuration for the connector is shown in the table below.

Table 4 BACKLIGHT CONNECTOR PIN CONFIGURATION

Pin	Symbol	Description	Notes
1	HV	Lamp power input	1
2	NC	No connect	
3	LV	Ground	2

Notes: 1. The input power terminal is colored pink. Ground pin color is light pink.

**Product Specification (preliminary)**

2. The backlight ground should be common with Vss.

**Product Specification (preliminary)**
**6. Signal Timing Specification**

Parameter		Symbol	Value			Units	Notes
			Min.	Typ.	Max.		
Main Clock	Frequency	$f_{CLK} (= 1/t_{CLK})$	TBD	65.0	TBD	MHz	
	High duration	$t_{wCH}$	$0.45 t_{CLK}$	$0.5 t_{CLK}$	$t_{CLK}$	ns	
	Low duration	$t_{wCL}$	$0.45 t_{CLK}$	$0.5 t_{CLK}$	$0.55 t_{CLK}$	ns	
	Rise Time	$t_{rCLK}$	$t_{CLK}$	-	$t_{CLK}$	ns	
	Fall Time	$t_{fCLK}$	-	-	8	ns	
				-	-	8	
Data (RGB data including sync)	Set-up duration	$t_{SD}$	5.0	-	-	ns	for $f_{CLK}$
	Hold duration	$t_{HD}$	5.0	-	-	ns	for $f_{CLK}$ note 1
Hsync	Period	$t_{HP}$	(TBD)	20.7	-	$\beta_i$	
	Pulse Width	$t_{WH}$	(TBD)	1344	(TBD)	clock	clock
Vsync	Period	$t_{VP}$	(TBD)	16.7	-	msec	
	Pulse Width	$t_{VW}$	(TBD)	806	(TBD)	lines	lines
Data Enable	Set-up duration	$t_{SI}$	5.0	-	-	ns	for $f_{CLK}$
	Hold duration	$t_{HI}$	5.0	-	-	ns	for $f_{CLK}$
	Horizontal Back Porch	$t_{HBP}$	(TBD)	160	-	clock	
	Horizontal Period		(TBD)	1344	-	clock	
	Horizontal Front porch	$t_{HFP}$	(TBD)	24	-	clock	
	Vertical Back Porch	$t_{VBP}$	(TBD)	29	-	lines	
	Vertical Period		(TBD)	806	-	lines	
Vertical Front porch	$t_{VFP}$	(TBD)	3	-	lines		
Hsync- Clock phase difference		$t_{HC}$	$t_{CLK} - 10$	-	$t_{wCL}$	ns	
Hsync-Vsync phase difference		$t_{HV}$	-	-	$t_{HP} - t_{WH}$	ns	

Notes: 1. All data input shall be latched at falling edge of data clock.

**7. Signal Timing Waveforms**

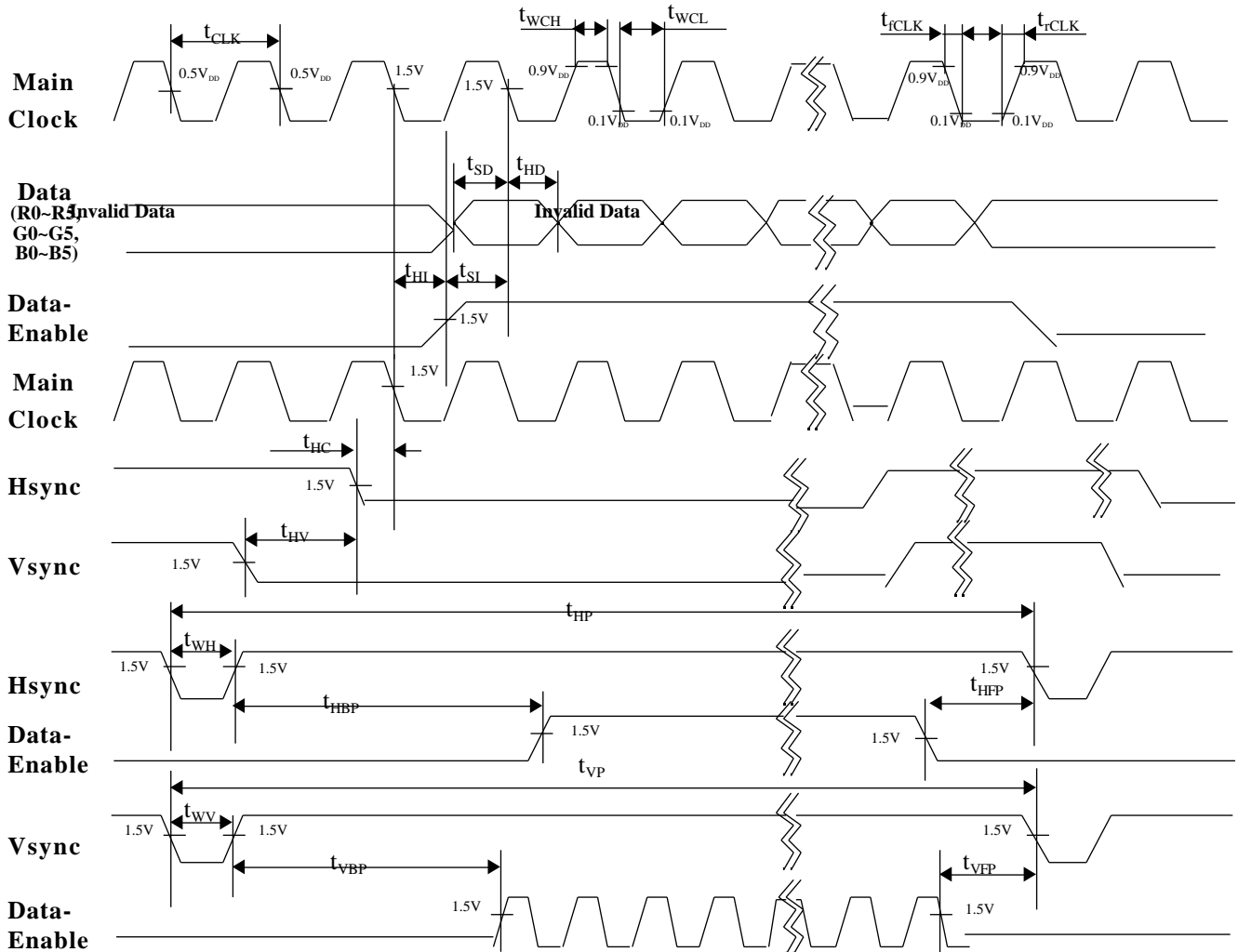

<b>Product Specification (preliminary)</b>
--

### 8. Color Input Data Reference

The brightness of each primary color (red, green and blue) is based on the 6-bit gray scale data input for the color; the higher the binary input, the brighter the color. The table below provides a reference for color versus data input.

Table 5 COLOR DATA REFERENCE

Color		Input Color Data																	
		Red						Green						Blue					
		MSB		LSB				MSB		LSB				MSB		LSB			
		R5	R4	R3	R2	R1	R0	G5	G4	G3	G2	G1	G0	B5	B4	B3	B2	B1	B0
Basic Colors	Black	0	0	0	0	0	0	0	0	0	0	0	0	0	0	0	0	0	0
	Red(63)	1	1	1	1	1	1	0	0	0	0	0	0	0	0	0	0	0	0
	Green(63)	0	0	0	0	0	0	1	1	1	1	1	1	0	0	0	0	0	0
	Blue(63)	0	0	0	0	0	0	0	0	0	0	0	0	1	1	1	1	1	1
	Cyan	0	0	0	0	0	0	1	1	1	1	1	1	1	1	1	1	1	1
	Magenta	1	1	1	1	1	1	0	0	0	0	0	0	1	1	1	1	1	1
	Yellow	1	1	1	1	1	1	1	1	1	1	1	1	0	0	0	0	0	0
	White	1	1	1	1	1	1	1	1	1	1	1	1	1	1	1	1	1	1
Red	Red(0) Dark	0	0	0	0	0	0	0	0	0	0	0	0	0	0	0	0	0	0
	Red(1)	0	0	0	0	0	1	0	0	0	0	0	0	0	0	0	0	0	0
	Red(2)	0	0	0	0	1	0	0	0	0	0	0	0	0	0	0	0	0	0
	:	:	:	:	:	:	:	:	:	:	:	:	:	:	:	:	:	:	:
	Red(61)	1	1	1	1	0	1	0	0	0	0	0	0	0	0	0	0	0	0
	Red(62)	1	1	1	1	1	0	0	0	0	0	0	0	0	0	0	0	0	0
	Red(63) Bright	1	1	1	1	1	1	0	0	0	0	0	0	0	0	0	0	0	0
Green	Green(0) Dark	0	0	0	0	0	0	0	0	0	0	0	0	0	0	0	0	0	0
	Green(1)	0	0	0	0	0	0	0	0	0	0	0	1	0	0	0	0	0	0
	Green(2)	0	0	0	0	0	0	0	0	0	0	1	0	0	0	0	0	0	0
	:	:	:	:	:	:	:	:	:	:	:	:	:	:	:	:	:	:	:
	Green(61)	0	0	0	0	0	0	1	1	1	1	0	1	0	0	0	0	0	0
	Green(62)	0	0	0	0	0	0	1	1	1	1	1	0	0	0	0	0	0	0
	Green(63) Bright	0	0	0	0	0	0	1	1	1	1	1	1	0	0	0	0	0	0
Blue	Blue(0) Dark	0	0	0	0	0	0	0	0	0	0	0	0	0	0	0	0	0	0
	Blue(1)	0	0	0	0	0	0	0	0	0	0	0	0	0	0	0	0	0	1
	Blue(2)	0	0	0	0	0	0	0	0	0	0	0	0	0	0	0	0	1	0
	:	:	:	:	:	:	:	:	:	:	:	:	:	:	:	:	:	:	:
	Blue(61)	0	0	0	0	0	0	0	0	0	0	0	0	1	1	1	1	0	1
	Blue(62)	0	0	0	0	0	0	0	0	0	0	0	0	1	1	1	1	1	0
	Blue(63) Bright	0	0	0	0	0	0	0	0	0	0	0	0	1	1	1	1	1	1

**9. Power Sequence**

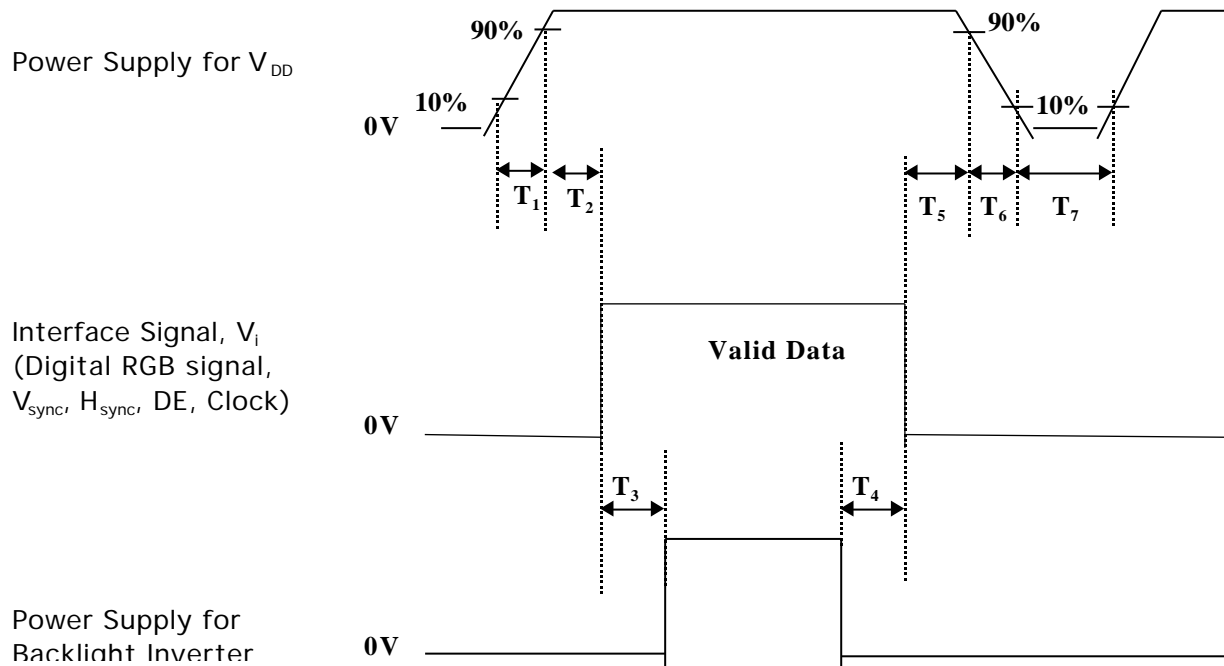

- n  $T_1, T_6$  : 10 ns ~ 20 ms.
- n  $T_2, T_5$  : 50 ms (min.)
- n  $T_3, T_4$  : 300 ms (min.)
- n  $T_7$  : TBD

- Notes:
1. Please avoid floating state of interface signal at invalid period.
  2. When the interface signal is invalid, be sure to pull down the power supply for LCD  $V_{DD}$  to 0V.
  3. BackLight inverter power must be turn on after power supply for LCD and interface signal are valid.





**Product Specification (preliminary)**

10. Mechanical Characteristics

The chart below provides general mechanical characteristics for the model LM151X2 LCD. Please refer to appendix 2 regarding the detailed mechanical drawing of the LCD module.

Parameter	Value	Symbol	Notes
Outside dimension Width Height Thickness	352.6 (typ) 264.6 (typ) 16.0 (typ)	mm	Thickness is 18.0mm(typ) at user connector
Bezel area Width Height	311.2 234.4	mm	
Active area Width Height	307.2 230.4	mm	
Weight	1500(typ) 1600 (max)	gram	
Front surface of LCD	Hard coating 3H. Anti-glare treatment of the front polarizer	-	



**Product Specification (preliminary)**

**11. Environmental Specification**

No	Test ITEM		Conditions
1	Temperature	Operating Non-operating	0°..~ 50°... -20°..~ 60°...
2	Humidity	Operating Non-operating	20% ~ 80% RH (non-condensing) 5% ~ 95% RH (38.7°.maximum wet bulb temperature)
3	Altitude		Operating : 12,000ft Storage : 40,000ft
4	Vibration test (non-operating)		Waveform : Random Vibration level : 1.5G RMS Bandwidth : 10~200Hz Duration : X, Y, Z, 20 min one time each direction
5	Shock test (non-operating)		Shock level : 100G Waveform: half sine wave, 2ms Direction : ±X, ±Y, ±Z one time each direction



## 12. Incoming Inspection Standard for TFT-LCD Modules

### 1. Scope

This incoming inspection standard shall be applied to TFT-LCD Modules(hereafter called "LCMs") supplied by LG Electronics Inc.(hereafter called the "Supplier") to Customer.

### 2. Incoming inspection

The Customer shall have the right to conduct at its own cost and expense, an incoming inspection of the LCMs at the destination specified in the relevant bills of lading in accordance with the LCM's specifications separately agreed upon and the inspection standard set forth in this article.

The Customer shall notify the Supplier in writing of the inspection results(acceptance or rejection) in accordance with the said inspection standard within 40 days after the date of the bills of lading.

Should Customer fail to so notify the Supplier within the said 40 days period, the Customer's right to reject the LCMs shall then lapse, and the said LCMs shall be deemed to have been accepted by the Customer.

### 3. Method of Incoming inspection

Unless otherwise agreed upon in writing, the sampling inspection method based on MIL-STD-105E shall be applied to the Customer's incoming inspection.

### 4. Classification of defects

Defects are classified as either a major defect or a minor defect based on the degree of defect defined herein.

#### a) Major defect

A major defect is a defect that is likely to result in product failure, or reduction in the product's intended usage.

#### b) Minor defect

A minor defect is a defect that has little bearing on the effective use or operation of the product.

Specific criteria of judgement of major and/or minor defects or other related issues shall be in accordance with the attached "Classification of Defects". (refer to appendix 4)

### 5. Acceptable Quality Level("AQL")

The AQL for major and minor defects shall be respectively set forth below.

a) Major defects : AQL = 0.65%

b) Minor defects : AQL = 1.5%

### 6. Sampling Inspection Method

a) Lot size : Quantity per shipment lot

b) Sampling type : Normal inspection, Single sampling

c) Inspection level : II

d) Sampling table : Table in MIL-STD-105E

### 7. Determination of acceptability and subsequent disposal

If the number of defects found in the LCM sampling lot is equal to or less than the applicable acceptance level, the lot shall be accepted.

If the number of defects is greater than the applicable acceptance level, the lot shall be rejected. The Customer shall inform the Supplier of the detailed results of such inspection within the time period stipulated in item #2 "Incoming inspection".

#### a) Accepted lot

An acceptance under the above incoming inspection shall constitute an acceptance by the Customer of such lot of the LCMs in terms of the landed quality thereof.

#### b) Rejected lot



**Product Specification (preliminary)**

If a shipment lot of products is rejected under the above incoming inspection due to any defects for which the Supplier is responsible and such a fact is clearly confirmed by the Supplier through a separate inspection or as otherwise decided, the Supplier shall choose one of the following three options which must be determined by mutual consent. The Supplier shall advise the Customer of its choice not later than 14 working days(Monday to Friday) of receipt of the "Customer's notification of rejected lot" :

- 1. The Customer shall return the rejected lot to the place to be designated by the Supplier and the Supplier shall screen all of the products in the lot and repair or replace the defective products.
- 2. The Supplier shall screen all of the products in the lot and repair or replace the defective products within a reasonable time period at the Customer's facility.
- 3. The Customer shall screen the entire lot for the good LCMs at the expense of the Supplier to be separately agreed upon. The rejected products shall be returned to the place designated by the Supplier.

**8. Inspection Specifications**

**a) General conditions**

**i) The environment conditions**

- Ambient temperature : 20~25°...
- Humidity : 65±5%RH
- Ambient illumination : Single 20W fluorescent lamp non-directive (About 300 to 700 Lux)

**ii) Viewing distance**

The distance between the LCM and the eyes of the inspector shall be at least 35cm.

**III) Inspection zone for external inspection**

External inspection should be performed from front side(Display area)

**b) External Inspection Standards**

Inspection items		Inspection Standards	Remark
Dent	Dot shape	D°0.5, N°8	On the polarizer
Scratches	Line shape	0.01°W°0.2, 5°L°20, N°4	On the polarizer
Stain inclusion	Dot shape	0.2°D°0.5, N°5	Operating
	Line shape	0.05°W°0.1, 0.3°L°3.0, N°5	Operating

W : Width(mm)  
L : Length(mm)  
D : Average diameter(mm)

Note) Those extraneous substances which can be wiped out easily are acceptable.

**c) Display-on Inspection(Visual inspection)**

**i) Dot Defect**

- Bright Dot Defects : When the LCM is turned on, dots(sub-pixels) which appear bright in the display area at Black(Dark) Mode are bright dot defects.
  - R, G or B 1 dot : 6 Max.
  - R, G or B join 2 dots : 1 Max.
  - R, G or B join 3 dots : 0 max.
  - Minimum Distance between defects : D ° 10mm
  - Total amount of Bright dot defects : 6 Max.
- Black Dot defects : When the LCM is turned on, dots(sub-pixels) which appear black in the display area at White(Bright) Mode are black dot defects.
  - 1 dot : 6 Max.
  - Join 2 dots : 1 Max.



**Product Specification (preliminary)**

- Join 3 dots : 0 max.
- Minimum Distance between defects :  $D \geq 10\text{mm}$
- Total amount of Black dot defects : 6 Max.

- Total amount of Dot Defect(Bright and Black Dot) : 10 Max. (Combination)

ii) Line Defect

All line defects such as vertical, horizontal or cross line defect are not allowed.

Note 1) Dot Defect : Defected area  $> 1/2$  dot

2) 1 Dot : Defect dot is isolated, not attached to other defect dot.

3) 3 Join N Dot : N dots are consecutive. (N means the number of defect dots)

9. Other

If any problems arise with the LCM supplied by LGE, the Customer and Supplier will cooperate and make efforts to solve it with mutual confidence and respect.



**Product Specification (preliminary)**

13. Designation of Lot Mark

a) Lot Mark

A	B	C	D	E	F	G	H	I	J	K	L
---	---	---	---	---	---	---	---	---	---	---	---

A, B : DIVISION CODE  
 C, D, E : MODEL CODE  
 F : YEAR  
 G : MONTH  
 H, I, J, K, L : SERIAL NO.

Note : 1. YEAR

YEAR	89	90	91	92	93	94	95	96	97	98	99
Mark	9	0	1	2	3	4	5	6	7	8	9

2. MONTH

MONTH	Jan.	Feb.	Mar.	Apr.	May	Jun.	Jun.	Aug.	Sep.	Oct.	Nov.	Dec.
Mark	1	2	3	4	5	6	7	8	9	0	N	D

b) Location of Lot Mark

Serial NO. Is printed on the label. The label is attached to the backside of the LCD module.  
 This is subject to change without prior notice.

14. Packing Form

a) Package quantity in one box : 8 pcs

b) Box Size : 587mm°408mm°378mm

Note : 1. Please, refer to appendix 3 regarding the detailed packing assembly drawing.



## 15. PRECAUTIONS

Please pay attention to the followings when you use this TFT-LCD module with Back-light unit.

- 1) You must mount Module using mounting holes arranged in 4 corners.
- 2) Be sure to turn off the power when connecting or disconnecting the circuit.
- 3) Note that the polarizers are easily damaged. Pay attention not to scratch or press this surface with any hard object.
- 4) When the LCD surface become dirty, please wipe it off with a soft material. (ie. cotton ball)
- 5) Protect the module from the ESD as it may damage the electronic circuit (C-MOS).  
Make certain that treatment person's body are grounded through wrist bend.
- 6) Do not disassemble the module and be careful not to incur a mechanical shock that might occur during installation. It may cause permanent damage.
- 7) Do not leave the module in high temperatures, particularly in areas of high humidity for a long time.
- 8) The module not be expose to the direct sunlight.
- 9) Avoid contact with water as it may a short circuit within the module.
- 10) Do not apply invalid signal, especially very high frequency data clock and  $H_{sync}$ . Invalid signal causes improper shutdown of DC/DC converter in LCM or permanent damage to LCD module. (  
(If DC/DC converter in LCM is in shutdown state, LCM shows only white screen. Then please turn off and on once LCM power.)
- 11) If the LCM displays the same pattern continuously for a long period of time, it can be the image sticking to the screen.





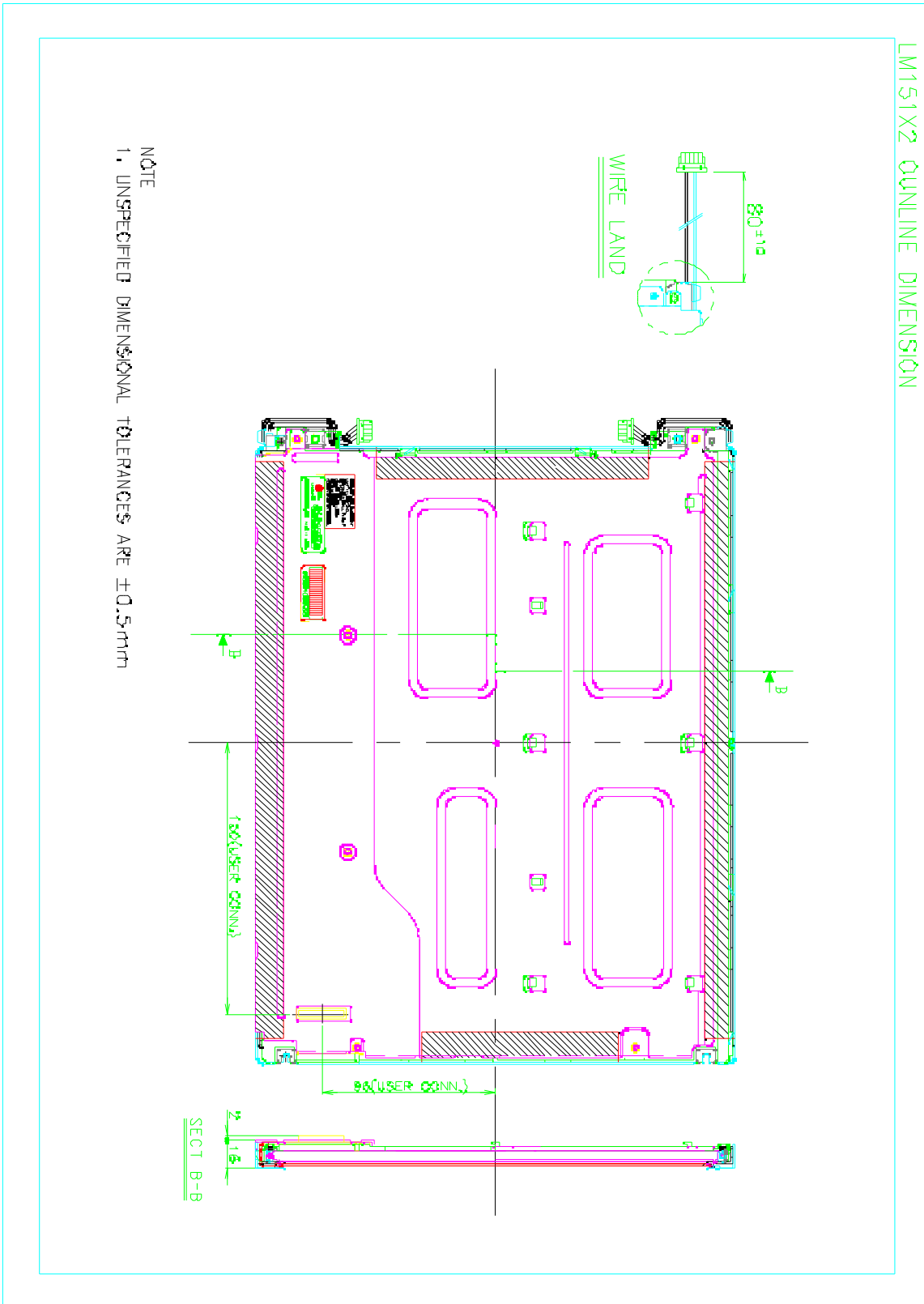

**Product Specification (preliminary)**

17. APPENDIX 2 : Packing Assembly Drawing

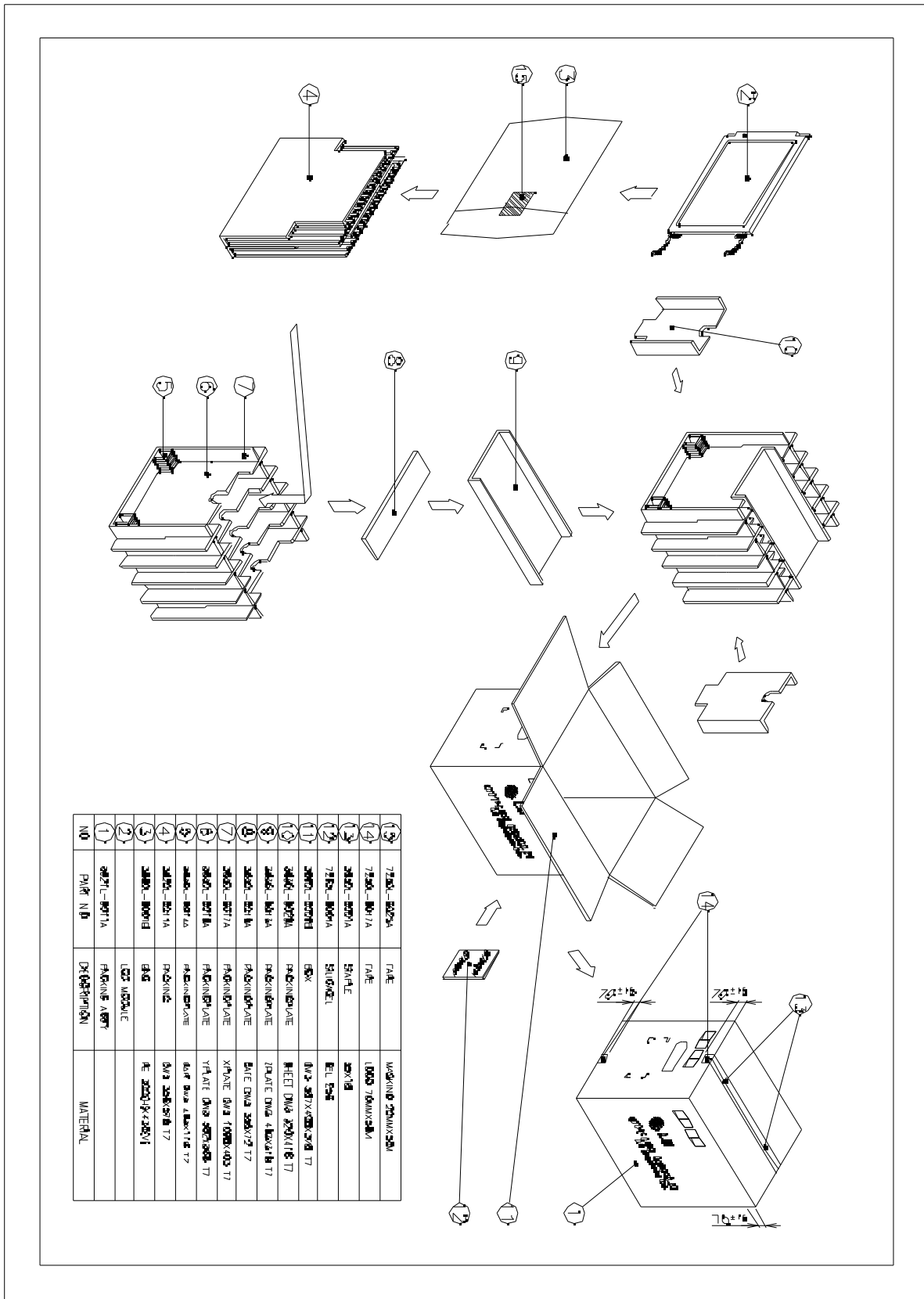

**Product Specification (preliminary)**

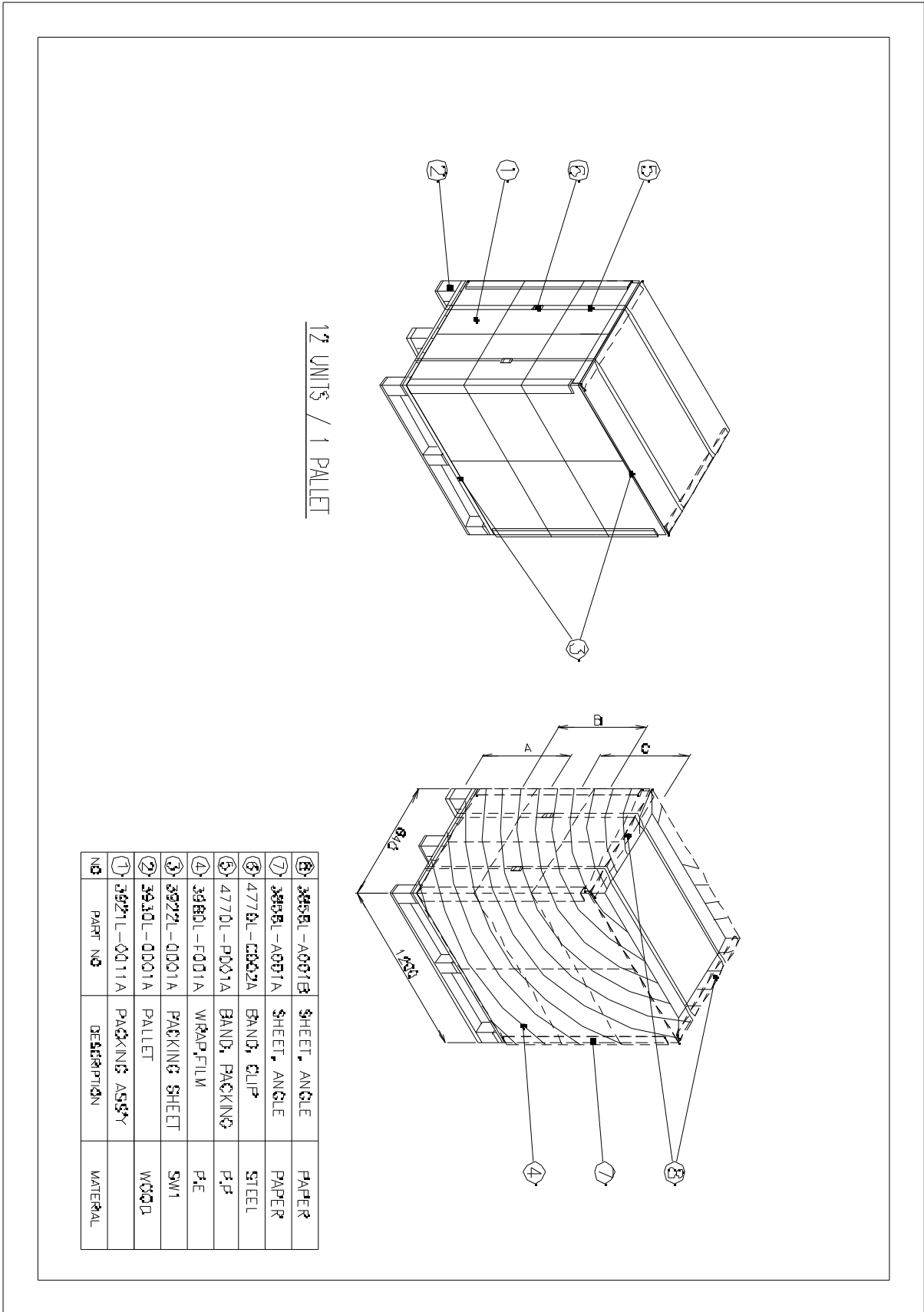

**Product Specification (preliminary)**
**18. APPENDIX 3 : Classification of Defects**

Inspection Item	Criterion for Defect	Type
Operating Frequency	Does not meet specified range in the spec.	Major
Power Consumption	Does not meet specified range in the spec.	Major
Contrast Ratio	Does not meet specified range in the spec.	Major
Line Defect	Vertical line defect Horizontal line defect Cross line defect	Major
Scratches, Dents or Bubbles	Shall be accordance with the item 8.b) "External inspection standards" on this incoming inspection standard	Minor
Extraneous Substance	Shall be accordance with the item 8.b) "External inspection standards" on this incoming inspection standard	Minor
Dot Defect	Shall be accordance with the item 8.b) "External inspection standards" on this incoming inspection standard	Minor
Bezel Appearance	Deep damage is found on plating, the ground metal is exposed, or rust may occur. (Irregular plating or coating is ignored)	Minor
Damaged Parts	a) The lead wire part is disconnected b) The lead wire part is not yet disconnected, but is damaged c) Function, performance or product value is impaired	Major Minor Major
Bezel Claw Forming	a) Bezel claw missing b) The bezel claw is not formed sufficiently	Major Minor